

PARANCO ELETTRICO A CATENA

Serie KF - Tipo KF/2S

Con carrello a spinta

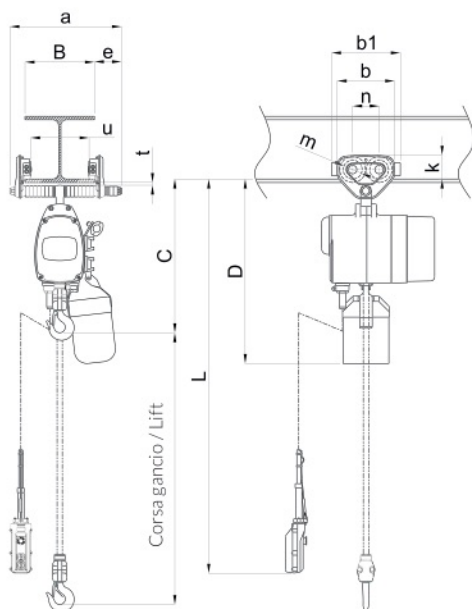

- Alimentazione 230-400V / 50-60Hz
- Apparecchiatura in bassa tensione 48 V
- Protezione paranco IP 54
- Catena zincata resistente alla fatica e alla corrosione
- Sacco raccogliacatena
- Ruote carrello su cuscinetti lubrificati a vita
- Carico sempre distribuito sulle 4 ruote poiché le piastre ruotano sul perno del carrello
- Staffe antiscarruolamento
- Respingenti in gomma
- Idonei a scorrere su travi ad ali piatte o inclinate grazie al profilo delle ruote

	Portata t	Tipo	Corsa gancio STD m	Cavo pulsantiera STD L m	Velocità sollevamento 50 Hz m/min.	Motore sollevamento		Larghezza trave B		Raggio minimo curvatura mm	Peso netto Kg
						Potenza kW	R.I. %	Standard mm	Option mm		
1 vel. sollev. 1 speed	125 kg	KF 20S1/2S	3.0	2.0	8.0	0.45	50	50÷163	164÷305	1100	33
	250 kg	KF 20S2/2S	3.0	2.0	4.0	0.45	50	50÷163	164÷305	1100	37
	250 kg	KF 25S1/2S	3.0	2.0	8.0	0.45	50	50÷163	164÷305	1100	33
	500 kg	KF 25S2/2S	3.0	2.0	4.0	0.45	50	50÷163	164÷305	1100	37
	500 kg	KF 50S1/2S	3.0	2.0	7.0	0.80	50	50÷163	164÷305	1100	46
	1	KF 50S2/2S	3.0	2.0	3.5	0.80	50	58÷163	164÷305	1300	54
	1	KF 100S1/2S	3.0	2.0	6.5	1.50	50	58÷163	164÷305	1300	66
	2	KF 100S2/2S	3.0	2.0	3.3	1.50	50	82÷204	205÷305	1500	76
2 vel. sollev. 2 speed	125 kg	KF 20S1A/2S	3.0	2.0	10/3.3	0.30/0.10	40/40	50÷163	164÷305	1100	33
	250 kg	KF 20S2A/2S	3.0	2.0	5.0/1.7	0.30/0.10	40/40	50÷163	164÷305	1100	37
	250 kg	KF 25S1A/2S	3.0	2.0	8.0/2.7	0.45/0.15	40/40	50÷163	164÷305	1100	33
	500 kg	KF 25S2A/2S	3.0	2.0	4.0/1.3	0.45/0.15	40/40	50÷163	164÷305	1100	37
	500 kg	KF 50S1A/2S	3.0	2.0	7.0/2.3	0.80/0.27	40/40	50÷163	164÷305	1100	46
	1	KF 50S2A/2S	3.0	2.0	3.5/1.2	0.80/0.27	40/40	58÷163	164÷305	1300	54
	1	KF 100S1A/2S	3.0	2.0	6.5/2.2	1.50/0.50	40/40	58÷163	164÷305	1300	66
	2	KF 100S2A/2S	3.0	2.0	3.3/1.1	1.50/0.50	40/40	82÷204	205÷305	1500	76

• Tutti i modelli sono disponibili con comando diretto o in bassa tensione. Su richiesta carrelli per raggi di curva inferiori.

	Portata t	Tipo	Ingombro minimo C mm	Dimensioni										
				D mm	a mm	b mm	b1 mm	e mm	g mm	k mm	m mm	n mm	t mm	u mm
1 vel. sollev. 1 speed	125 kg	KF 20S1/2S	500	600 [690]	204	182	212	46	24	76	60	84	19	B-45
	250 kg	KF 20S2/2S	540	600 [690]	204	182	212	46	24	76	60	84	19	B-45
	250 kg	KF 25S1/2S	500	600 [690]	204	182	212	46	24	76	60	84	19	B-45
	500 kg	KF 25S2/2S	540	600 [690]	204	182	212	46	24	76	60	84	19	B-45
	500 kg	KF 50S1/2S	550	740 [820]	204	182	212	46	34	76	60	84	19	B-45
	1	KF 50S2/2S	630	755 [835]	249	236	272	46	31	95	71	112	28	B-48
	1	KF 100S1/2S	625	860 [900]	249	236	272	56	31	95	71	112	28	B-48
	2	KF 100S2/2S	775	940 [980]	300	280	316	69	37	112	85	131	34	B-57
2 vel. sollev. 2 speed	125 kg	KF 20S1A/2S	500	600 [690]	204	182	212	46	24	76	60	84	19	B-45
	250 kg	KF 20S2A/2S	540	600 [690]	204	182	212	46	24	76	60	84	19	B-45
	250 kg	KF 25S1A/2S	500	600 [690]	204	182	212	46	24	76	60	84	19	B-45
	500 kg	KF 25S2A/2S	540	600 [690]	204	182	212	46	24	76	60	84	19	B-45
	500 kg	KF 50S1A/2S	550	740 [820]	204	182	212	46	34	76	60	84	19	B-45
	1	KF 50S2A/2S	630	755 [835]	249	236	272	46	31	95	71	112	28	B-48
	1	KF 100S1A/2S	625	860 [900]	249	236	272	56	31	95	71	112	28	B-48
	2	KF 100S2A/2S	775	940 [980]	300	280	316	69	37	112	85	131	34	B-57

• Le dimensioni () della quota "D" è riferita a paranchi con sacco raccogliacatena grande.