

GRILLI AD OMEGA “SLING”

Con dado e coppiglia - Modello P-6033

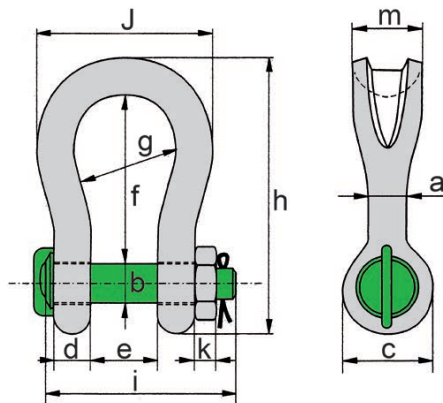

Codice	Portata WLL t	Dimensioni												Peso Kg
		a mm	b mm	c mm	d mm	e mm	f mm	g mm	h mm	i mm	J mm	k mm	m mm	
GDC-0007TGPSL	7	22	22	46	19	32	96	64	153	115	110	19	41	2
GDC-0012TGPSL	12,5	28	28	61	25	44	121	82	197	151	146	24	54	4
GDC-0018TGPSL	18	35	35	69	30	52	147	102	239	165	180	29	64	7
GDC-0030TGPSL	30	40	42	90	35	69	165	126	279	207	200	34	79	13
GDC-0040TGPSL	40	55	51	109	45	84	200	140	331	252	235	38	97	21
GDC-0055TGPSL	55	60	57	115	55	90	240	160	389	294	270	45	100	30
GDC-0075TGPSL	75	68	70	125	54	110	290	185	473	327	317	54	120	48
GDC-0125TGPSL	125	85	80	154	85	137	366	220	583	426	390	64	150	92
GDC-0150TGPSL	150	94	95	179	89	147	391	253	645	435	434	50	170	140
GDC-0200TGPSL	200	110	105	199	100	158	481	280	759	470	482	50	205	205
GDC-0250TGPSL	250	126	120	227	110	179	542	300	859	519	530	60	240	264
GDC-0300TGPSL	300	135	134	245	122	195	601	350	947	575	620	70	265	360
GDC-0400TGPSL	400	160	160	293	145	231	576	370	985	675	690	80	320	580
GDC-0500TGPSL	500	170	180	328	160	263	681	450	1131	748	790	90	340	780
GDC-0600TGPSL	600	190	200	348	170	289	741	490	1234	809	865	100	370	980
GDC-0700TGPSL	700	200	215	392	190	315	751	540	1284	879	901	100	400	1360
GDC-0800TGPSL	800	218	230	420	200	342	851	554	1426	942	947	110	420	1430
GDC-0900TGPSL	900	242	255	466	220	368	851	580	1488	1023	1023	120	440	1650
GDC-1000TGPSL	1000	260	270	490	240	399	851	614	1532	1103	1107	120	460	2970
GDC-1250TGPSL	1250	285	300	510	260	452	931	650	1666	1227	1182	150	530	3700
GDC-1500TGPSL	1500	285	320	550	280	483	950	680	1710	1300	1253	150	560	4000

- Acciaio legato ad alta resistenza grado 8
- Finitura: zincatura a caldo
- Temperatura di lavoro: -20°C ÷ 200°C
- Coefficiente di sicurezza 5:1
- Conforme alla direttiva macchine 2006/42/CE
- Migliora notevolmente la vita delle brache in fune metallica.
- L'aumento del raggio della sella del grillo permette l'aumento della superficie di appoggio della fune senza necessità di una redancia.
- Rispetto al grillo tradizionale riduce la perdita di portata dovuta all'avvolgimento delle funi su curvature di piccolo raggio.

